

The following document describes the location and operation of the plumbing equipment and its functions for the 2022 inTech Sol Horizon. This includes valve orientations for the following usages:

1. Using on board water tank or city water.
2. Draining the system (prep for Winterizing)
3. Winterizing

The below diagrams show all the valves and water pumps for the Sol Horizon plumbing system.

Three Operations of the Plumbing System

1. Using on board water tank or city hookup.

- 1-By-Pass Valve - OPEN
- 2-Hot Water Drain - CLOSED
- 3- Fresh Tank Drain – CLOSED
- 4- Main Drain – CLOSED
- 5- Winterization Valve – CLOSED
- 6-Hot Water Tank Bypass Valves-Facing Hot Water Heater

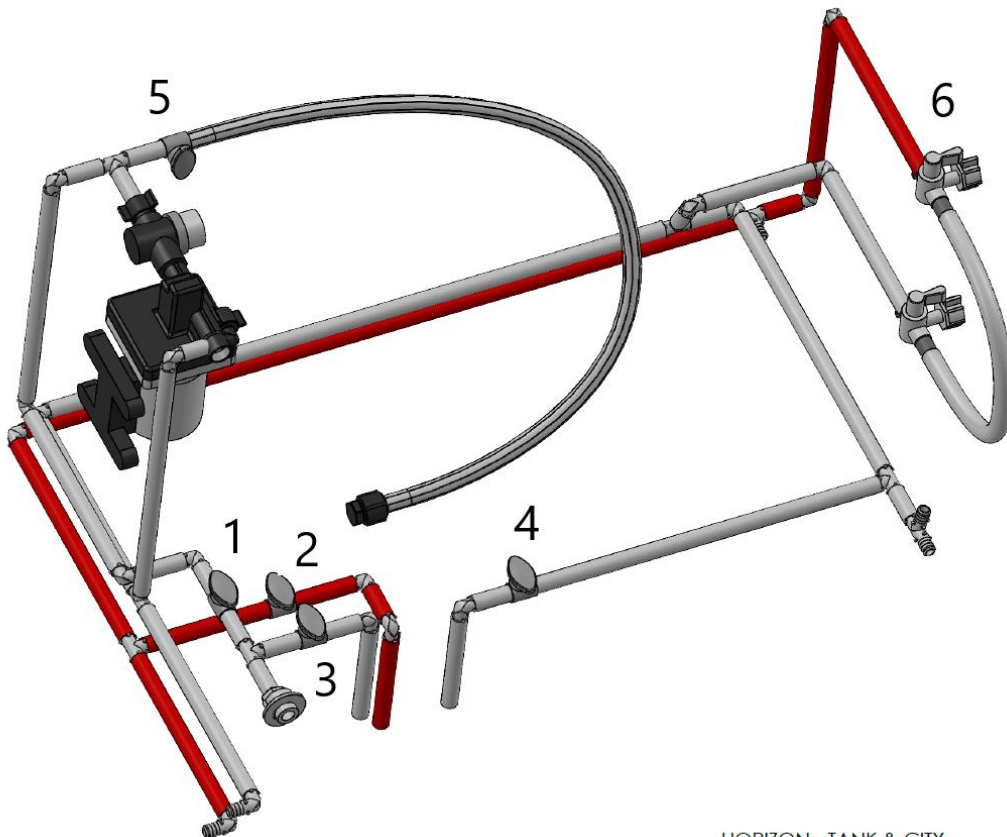

HORIZON - TANK & CITY

2. Draining the system (Prep for Winterizing)

Drain the water tank, leave the faucets open, and get as much water out of the unit as possible. To make sure all the water is out of the system, the lines can be kept open for a few hours.

Also, drain the water out of the hot water heater by removing the anode before storing for winter.

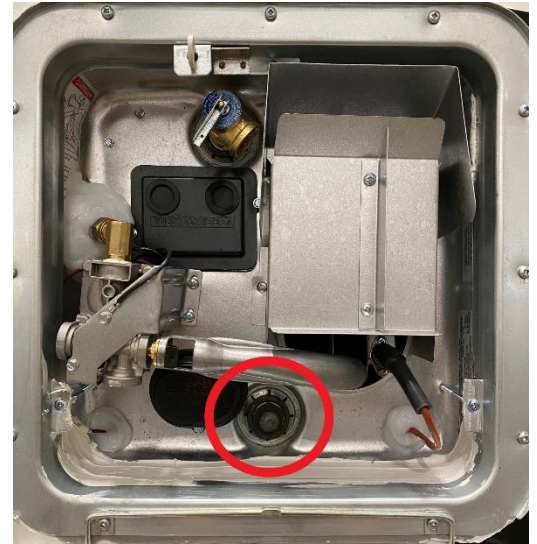

- 1-By-Pass Valve - OPEN
- 2-Hot Water Drain - OPEN
- 3- Fresh Tank Drain – OPEN
- 4- Main Drain – OPEN
- 5- Winterization Valve – CLOSED
- 6-Hot Water Tank Bypass Valves-Facing Hot Water Heater

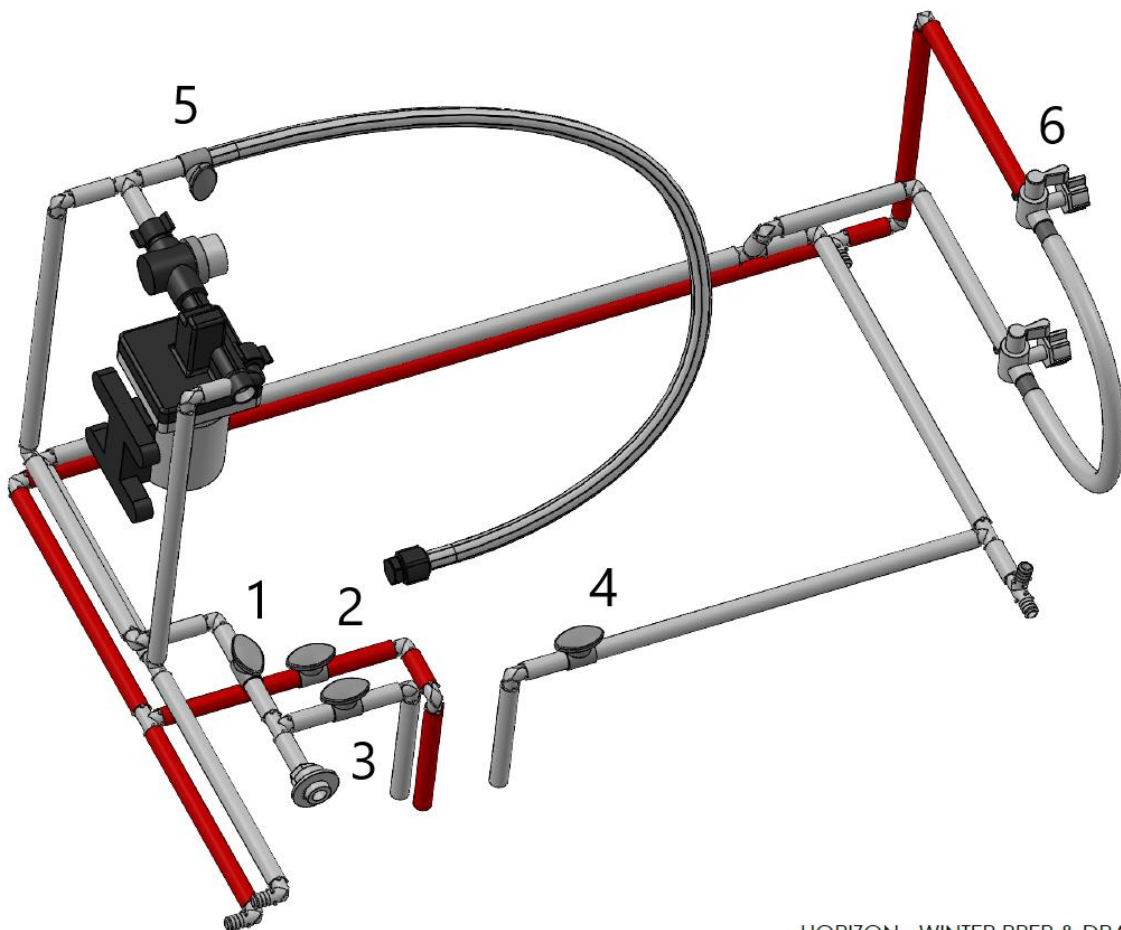

HORIZON - WINTER PREP & DRAIN

3. Winterizing

Pumping non-toxic RV antifreeze into the system, will help protect the lines. The valves need to be closed, so RV antifreeze does not pump into the tank or hot water heater. Dip the winterizing hose into the RV antifreeze, then turn on the pump. Go around to the sink, shower faucet, and toilet and run until you get antifreeze through each of them. Once you have fluid run through the whole system turn the pump off. Make sure about a cup or more of RV antifreeze runs down the sink to get into the “P” traps of the sink and toilet. Once the RV antifreeze is pumped through the system, close the winterization valve.

1-By-Pass Valve - CLOSED

2-Hot Water Drain - CLOSED

3- Fresh Tank Drain – CLOSED

4- Main Drain – CLOSED

5- Winterization Valve – OPEN

6-Hot Water Tank Bypass Valves-Inline with the Bypass tubing
(Do NOT put antifreeze into the Hot Water Tank)

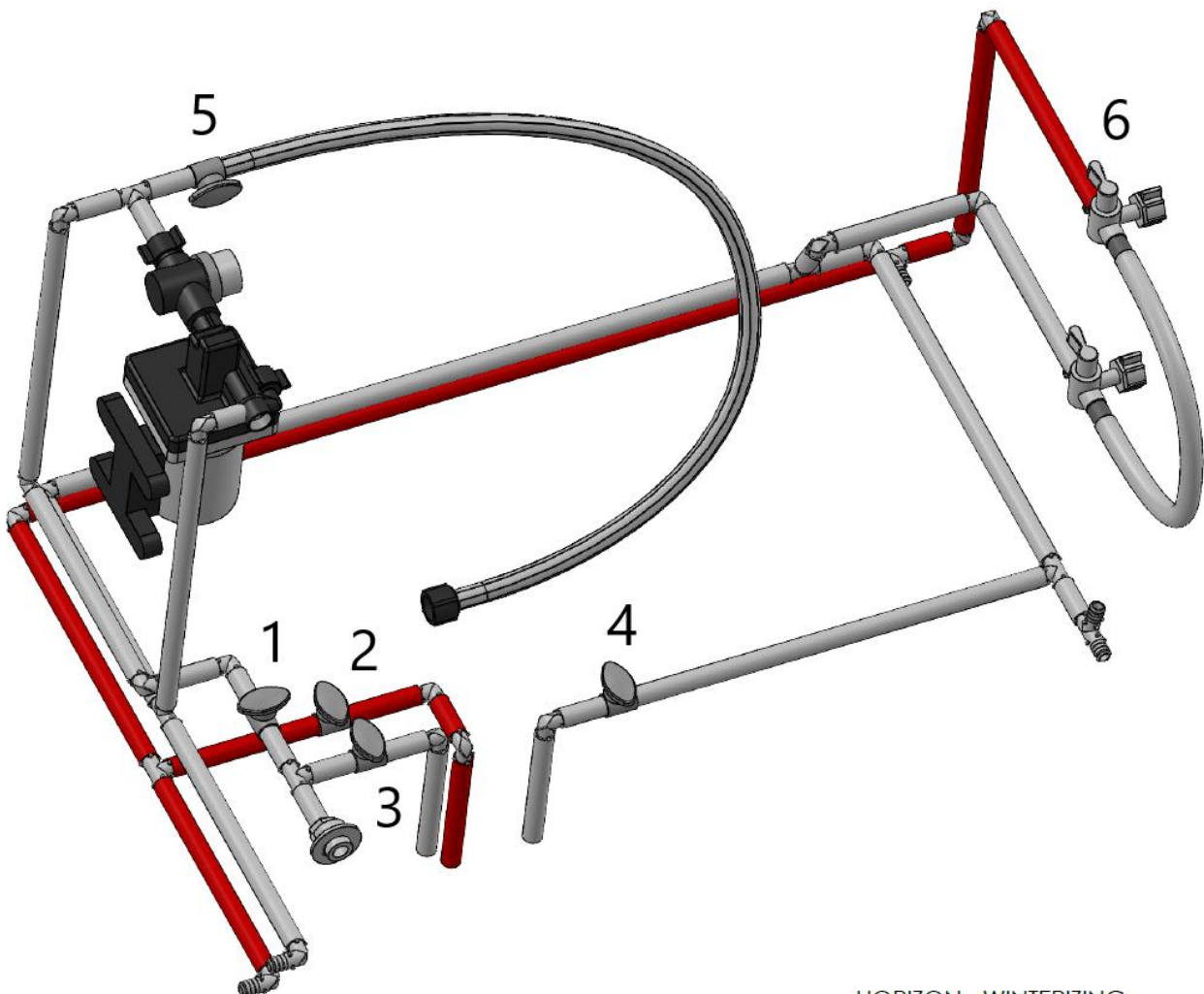

HORIZON - WINTERIZING