

ITEM NO.	DESCRIPTION	NOTES	Option/QTY.
1	Air Conditioner	13,500 BTU	1
2	Axle, Dexter	5200#, 10 UP, 94HF, 78AB	2
13	BTL L-Base Cabinet		1
14	BTL Overhead Cabinet TH		1
15	Bar Lock -		2
16	Battery Box		1
17	Battery Vent		1
18	Bumpers	1"	1
19	Cast Corners		1
20	Caster Wheel		2
23	Coupler	2 5/16" Ball, 14,000#	1
24	D-Ring		4
25	Door, Entrance	48" x 78" RHS	1
27	Generator Door	40" x 36"	1
28	Jack - Power		1
29	LED Light	18", 12V, LED	6
30	Load Center	30 Amp L/C - 45 Amp Conv	1
31	Loading Light - LED	18" 12V Loading Light	2
32	Motorbase Plug	30 Amp	1
33	Outlet	120V 20 Amp	4
34	Ramp Extension	16" Transition Flap	1
37	Slide Out Step	48" Wide	1
38	Spare Tire Assembly		1
39	Switch	1 - 12V Switch	1
40	Switch	12v Cutoff	1
42	Tire	ST225/75R15	4
43	Vent, Roof		1
45	Winch Plate		1

	NAME	DATE	<i>inTech Trailers</i>	
DRAWN	SMM	2/25/19	INTECH BTL8.5x24TA3 - OPTIONS BOM	
CHECKED				
ENG APPR.				
<small>ALL DIMENSIONS ARE IN INCHES AND ARE NOMINAL. DIMENSIONS ON ACTUAL TRAILER MAY VARY FROM WHAT IS SHOWN ON PRINT BASED ON ACTUAL FRAMING AND TRAILER STRUCTURE. UNLESS NOTED AS CRITICAL.</small>			DWG. NO.	REV.
			BTL8.5x24TA3 Trailer Assembly - Options	G
			SCALE: 1:50	SHEET 1 OF 5

PROPRIETARY AND CONFIDENTIAL
 THE INFORMATION CONTAINED IN THIS DRAWING IS THE SOLE PROPERTY OF INTECH TRAILERS. ANY REPRODUCTION IN PART OR AS A WHOLE WITHOUT THE WRITTEN PERMISSION OF INTECH TRAILERS IS PROHIBITED.

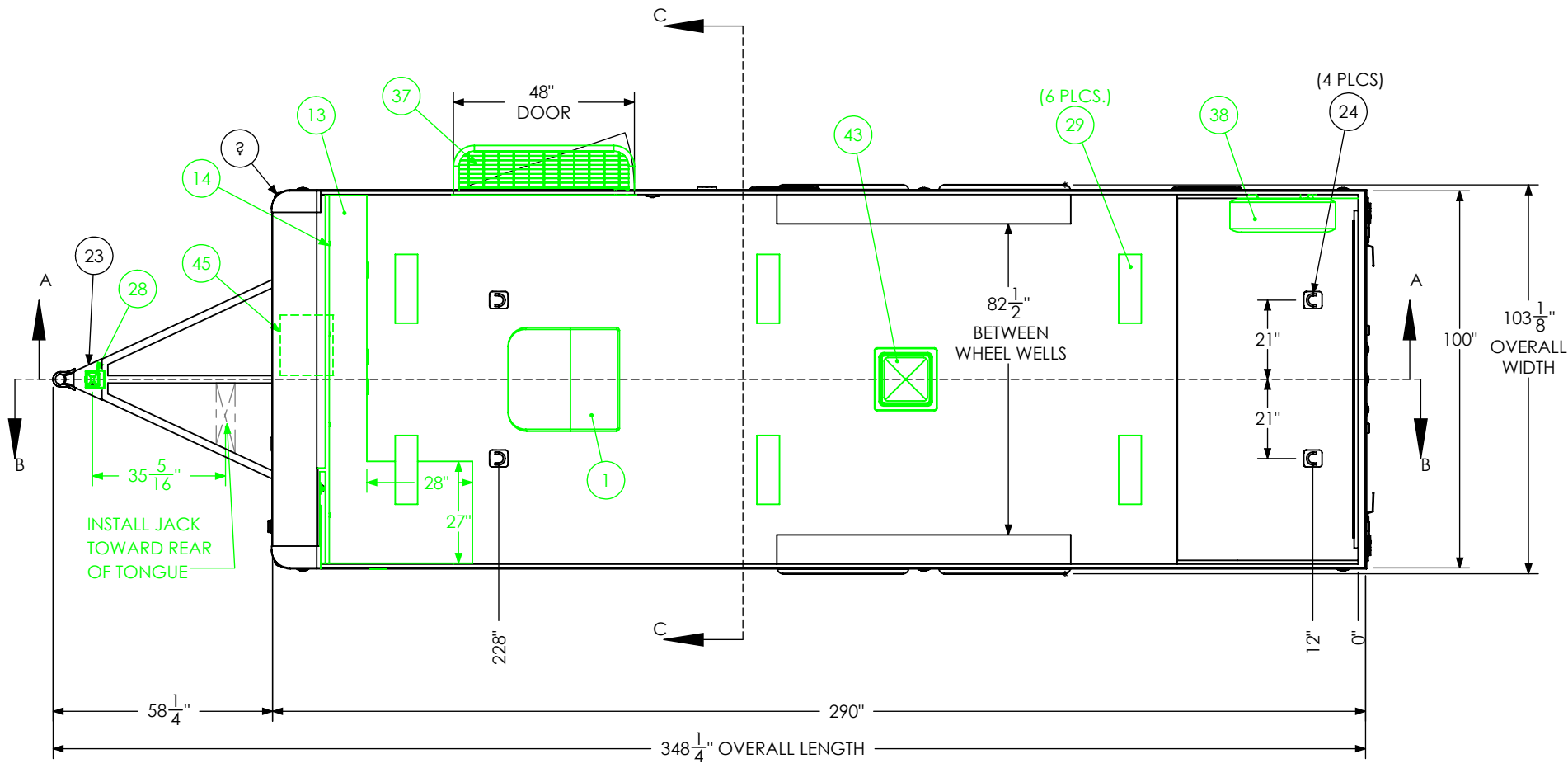

	NAME	DATE	inTech Trailers INTECH BTL8.5x24TA3 - OPTIONS FLOORPLAN	
DRAWN	SMM	2/25/19		
CHECKED				
ENG APPR.				
ALL DIMENSIONS ARE IN INCHES AND ARE NOMINAL. DIMENSIONS ON ACTUAL TRAILER MAY VARY FROM WHAT IS SHOWN ON PRINT BASED ON ACTUAL FRAMING AND TRAILER STRUCTURE. UNLESS NOTED AS CRITICAL.			DWG. NO.	REV.
			BTL8.5x24TA3 Trailer Assembly - Options	G
SCALE: 1:42			SHEET 2 OF 5	

PROPRIETARY AND CONFIDENTIAL
 THE INFORMATION CONTAINED IN THIS DRAWING IS THE SOLE PROPERTY OF INTECH TRAILERS. ANY REPRODUCTION IN PART OR AS A WHOLE WITHOUT THE WRITTEN PERMISSION OF INTECH TRAILERS IS PROHIBITED.

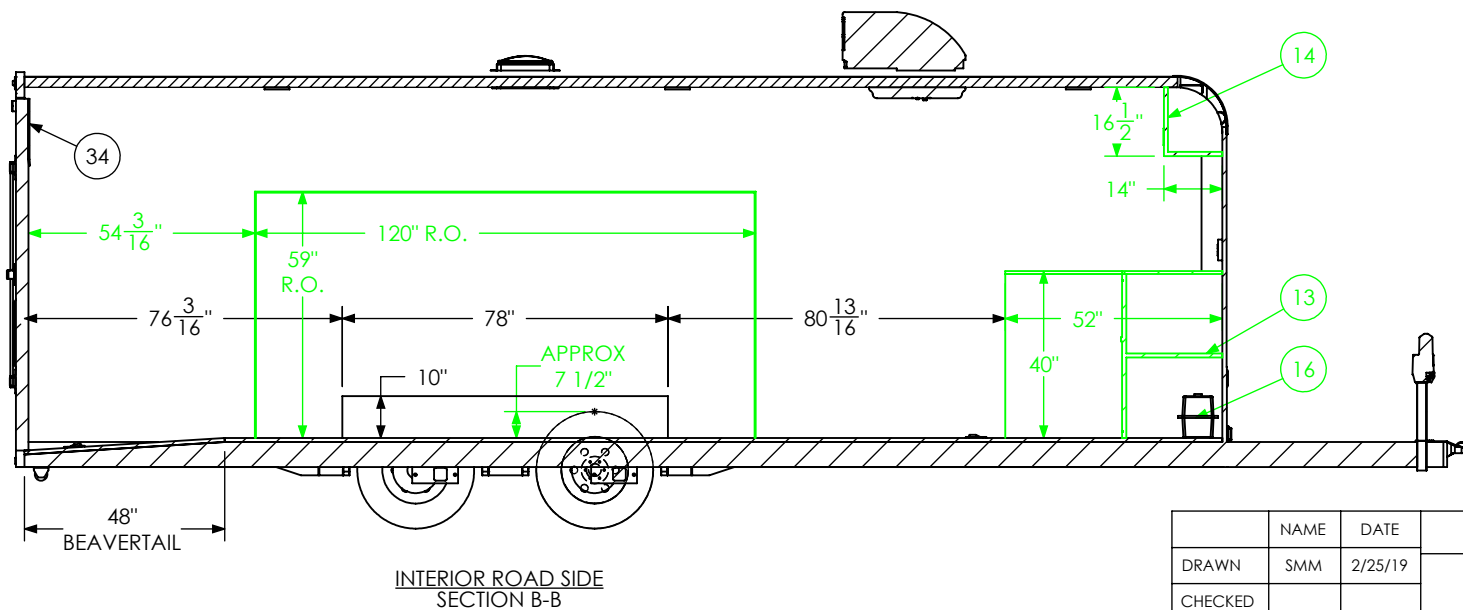
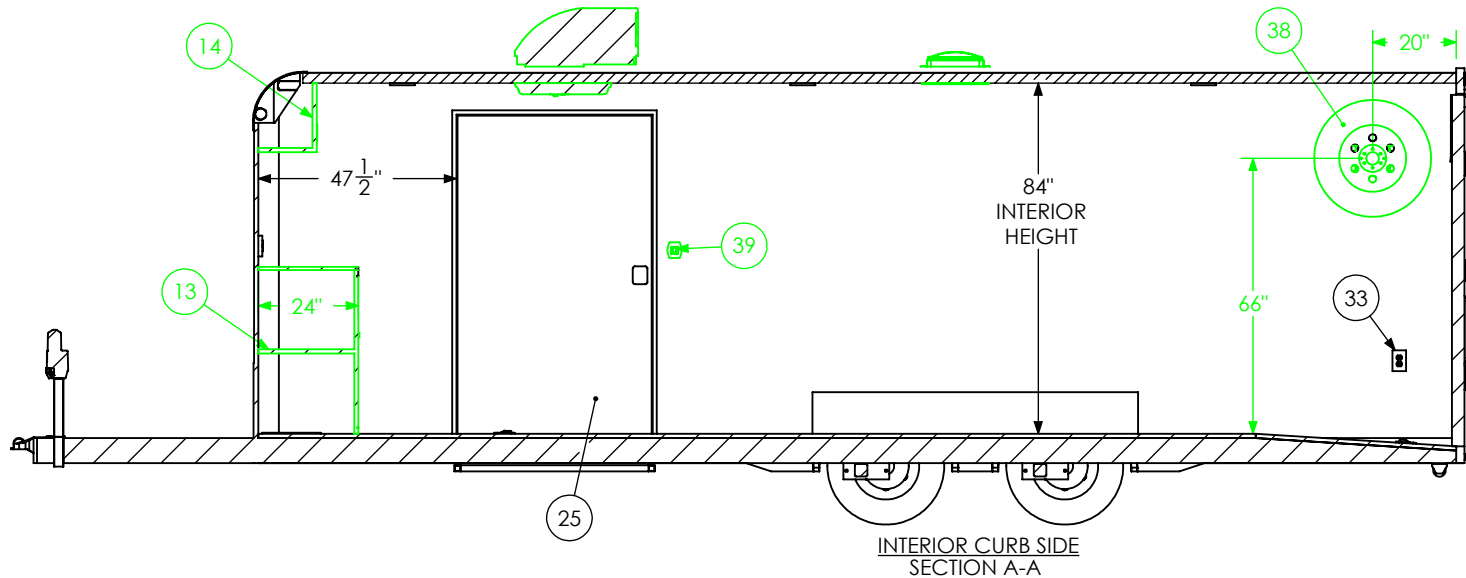

		NAME	DATE	inTech Trailers	
DRAWN	SMM	2/25/19		INTECH BTL8.5x24TA3 - OPTIONS INTERIOR SIDES	
CHECKED					
ENG APPR.					
ALL DIMENSIONS ARE IN INCHES AND ARE NOMINAL. DIMENSIONS ON ACTUAL TRAILER MAY VARY FROM WHAT IS SHOWN ON PRINT BASED ON ACTUAL FRAMING AND TRAILER STRUCTURE. UNLESS NOTED AS CRITICAL.			DWG. NO. BTL8.5x24TA3 Trailer Assembly - Options		REV. G
			SCALE: 1:46		SHEET 3 OF 5

PROPRIETARY AND CONFIDENTIAL
 THE INFORMATION CONTAINED IN THIS DRAWING IS THE SOLE PROPERTY OF INTECH TRAILERS. ANY REPRODUCTION IN PART OR AS A WHOLE WITHOUT THE WRITTEN PERMISSION OF INTECH TRAILERS IS PROHIBITED.

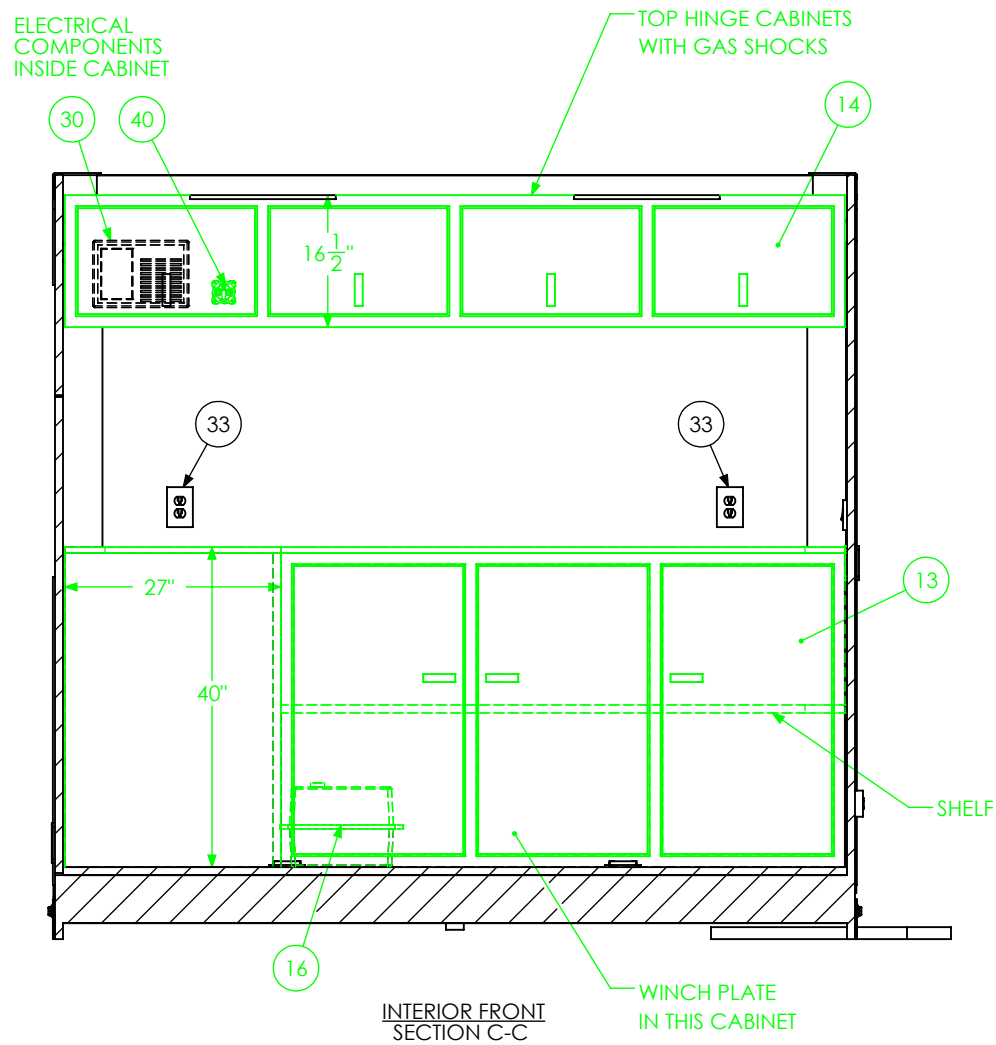

INTERIOR FRONT SECTION C-C

	NAME	DATE	inTech Trailers INTECH BTL8.5x24TA3 - OPTIONS INTERIOR FRONT	
DRAWN	SMM	2/25/19		
CHECKED				
ENG APPR.				
ALL DIMENSIONS ARE IN INCHES AND ARE NOMINAL. DIMENSIONS ON ACTUAL TRAILER MAY VARY FROM WHAT IS SHOWN ON PRINT BASED ON ACTUAL FRAMING AND TRAILER STRUCTURE. UNLESS NOTED AS CRITICAL.			DWG. NO. BTL8.5x24TA3 Trailer Assembly - Options	REV. G
			SCALE: 1:24	SHEET 4 OF 5

PROPRIETARY AND CONFIDENTIAL
THE INFORMATION CONTAINED IN THIS DRAWING IS THE SOLE PROPERTY OF INTECH TRAILERS. ANY REPRODUCTION IN PART OR AS A WHOLE WITHOUT THE WRITTEN PERMISSION OF INTECH TRAILERS IS PROHIBITED.

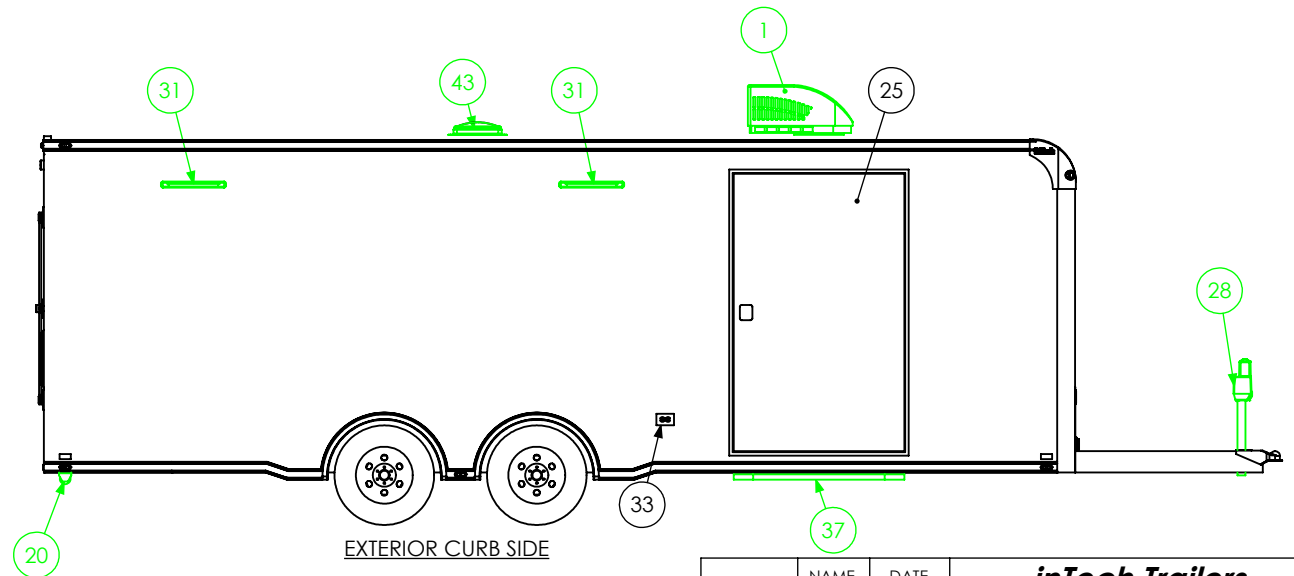
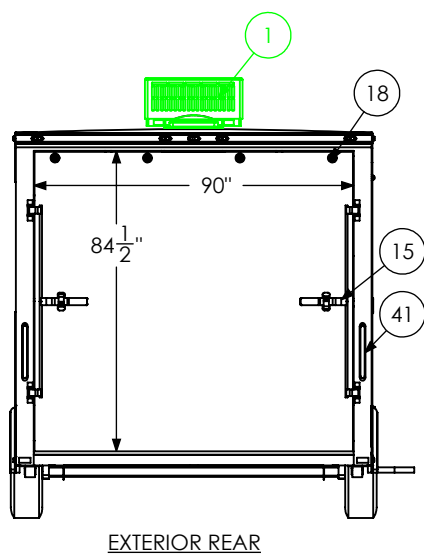
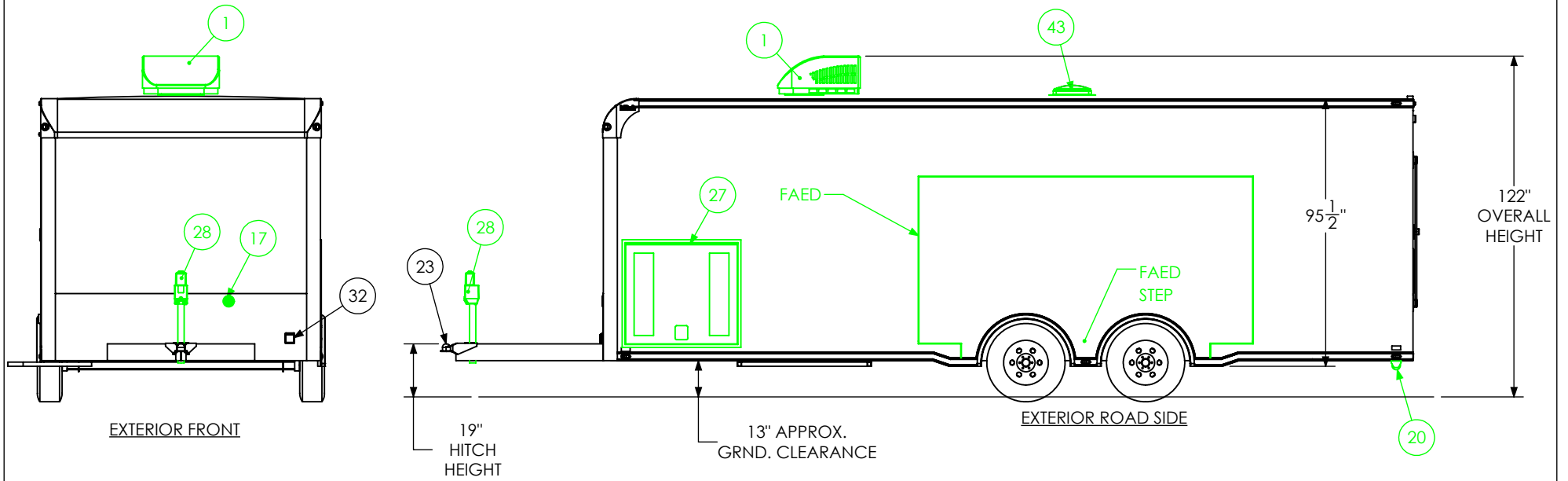

	NAME	DATE	inTech Trailers INTECH BTL8.5x24TA3 - OPTIONS EXTERIOR	
DRAWN	SMM	2/25/19		
CHECKED				
ENG APPR.				
ALL DIMENSIONS ARE IN INCHES AND ARE NOMINAL. DIMENSIONS ON ACTUAL TRAILER MAY VARY FROM WHAT IS SHOWN ON PRINT BASED ON ACTUAL FRAMING AND TRAILER STRUCTURE. UNLESS NOTED AS CRITICAL.			DWG. NO.	REV.
			BTL8.5x24TA3 Trailer Assembly - Options	G
SCALE: 1:54			SHEET 5 OF 5	

PROPRIETARY AND CONFIDENTIAL
 THE INFORMATION CONTAINED IN THIS DRAWING IS THE SOLE PROPERTY OF INTECH TRAILERS. ANY REPRODUCTION IN PART OR AS A WHOLE WITHOUT THE WRITTEN PERMISSION OF INTECH TRAILERS IS PROHIBITED.